

# APOLLO PILLAR™ (APL)



NEEDED FOR INSTALLATION:  
By Others

- 1/8" Allen Wrench
- Wire Connectors
- Mounting Hardware
- Gloves

## IMPORTANT SAFETY INFORMATION - READ, FOLLOW, AND SAVE THESE INSTALLATION INSTRUCTIONS



**IMPORTANT - WEAR GLOVES TO AVOID GETTING FINGERPRINTS ON THIS PRODUCT. MANY TEKA ILLUMINATION PRODUCTS ARE DESIGNED TO NATURALLY PATINA. OILS FROM YOUR SKIN WILL ACCELERATE THIS PROCESS WHERE TOUCHED AND ARE NEARLY IMPOSSIBLE TO REMOVE. THIS PROCESS OCCURS OVER TIME AND IS DETERMINED BY THE INSTALLATION ENVIRONMENT.**

**INSTRUCTIONS PERTAINING TO A RISK OF FIRE, OR INJURY TO PERSONS IMPORTANT SAFETY INSTRUCTIONS**

**Lighted fixture is HOT!**  
**WARNING - To reduce the risk of FIRE OR INJURY TO PERSONS:**  
 Turn off/unplug and allow to cool before replacing LED. Fixture gets HOT quickly! Contact only switch/plug when turning on. Do not touch hot lens, guard, or enclosure. Keep fixture away from materials that may burn. Do not operate the luminaire fitting with a missing or damaged shield. Do not touch the source at any time. Use a soft cloth or gloves. Oil from skin may cause damage.  
**SAVE THESE INSTRUCTIONS**

## IMPORTANT SAFETY INFORMATION - READ, FOLLOW, AND SAVE ALL SAFETY AND INSTALLATION INSTRUCTIONS

- Product must be installed by a qualified person in a manner consistent with its intended use and in compliance with the National Electrical Code, Canadian Electrical Code, and all Local and Provincial Codes.
- Follow product label information and instructions.
- Qualified Personnel with appropriate personal protective equipment must perform all servicing of this product.
- Before wiring to power supply and during servicing, turn off and lock out power at fuse or circuit breaker before service.
- The use of accessory equipment not recommended by the manufacturer or installed contrary to instructions may cause an unsafe condition. The use of damaged components may cause an unsafe condition and void product warranty.
- Do not block light emanating from product in whole or part, as this may cause an unsafe condition.
- Never operate the fixture with missing or damaged lens. Lens must be cleaned on regular basis.
- Entire fixture may become extremely hot. Do not touch hot lens or fixture body.
- Replace LED assembly only with correct wattage and type of power supply appropriate for LED assembly.
- All gaskets, o-rings and sealing surfaces must be kept clean during installation and service; failure to do this may cause an unsafe condition and void product warranty.

## IMPORTANT LISTINGS AND CERTIFICATIONS

- Suitable for wet locations

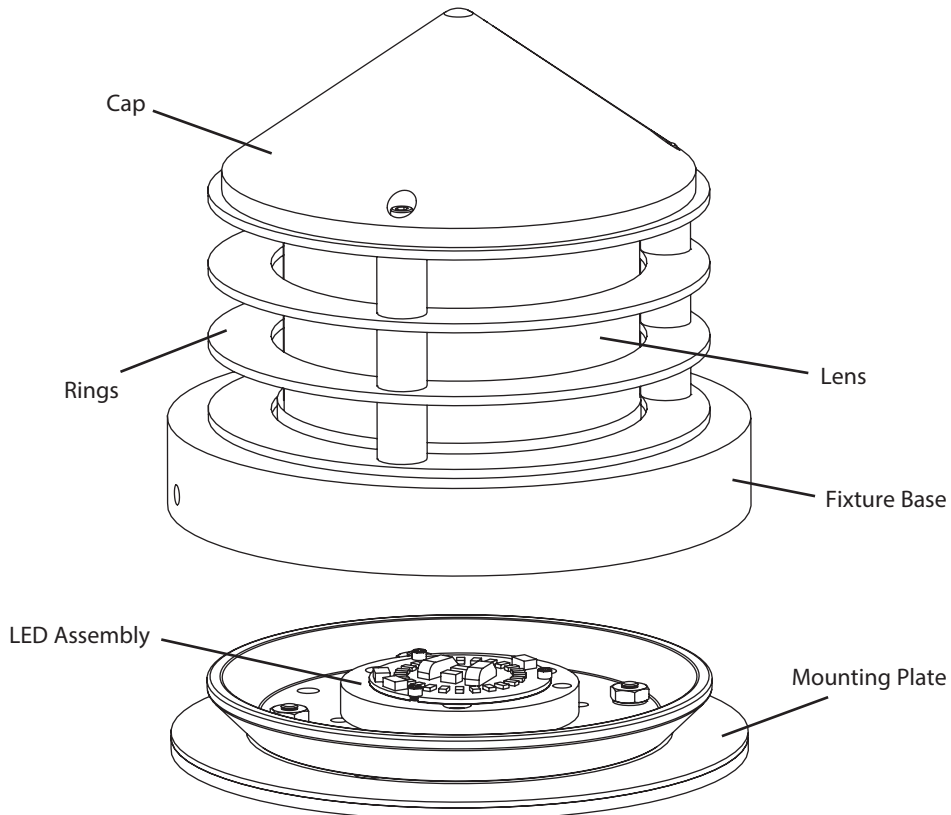

## IMPORTANT SAFETY INFORMATION - READ, FOLLOW, AND SAVE THESE INSTALLATION INSTRUCTIONS

<b>TEKA</b> ILLUMINATION	40429 Brickyard Drive • Madera, CA 93636 • USA	DATE	REFERENCE NUMBER
	559.438.5800 • FAX 559.438.5900 www.tekaillumination.com • info@tekaillumination.com	3-7-19	INS-2566-00

THIS DOCUMENT CONTAINS PROPRIETARY INFORMATION OF TEKA ILLUMINATION AND ITS RECEIPT OR POSSESSION DOES NOT CONVEY ANY RIGHTS TO REPRODUCE, DISCLOSE ITS CONTENTS, OR TO MANUFACTURE, USE OR SELL ANYTHING IT MAY DESCRIBE. REPRODUCTION, DISCLOSURE OR USE WITHOUT SPECIFIC WRITTEN AUTHORIZATION OF TEKA ILLUMINATION IS STRICTLY FORBIDDEN.

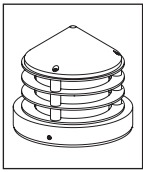

# APOLLO PILLAR™ (APL)

## Phase 1 - Rough In

Installation of Back box

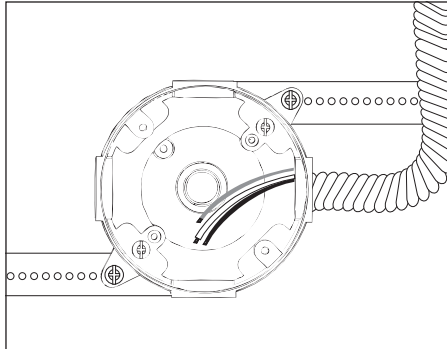

### Additional Info

- Please follow National and Local electrical codes for your area.
- Use 4" round cast box
- Suitable for through wire
- Suitable for installation into combustible materials.
- Rated for 90° C.
- Junction box, universal mounting ring screws, box mounting hardware and gaskets (By Others)



**Junction box must be secured to a structural member suitable for weight of the luminaire and other weight likely to be placed upon it.**

1. Install Conduit (By Others) to be used with this product.
2. Install junction box (By Others) so that front face is flush with finished wall.
3. Connect box to conduit and pull wires for connections (See wiring diagram).

## Phase 2 - Fixture Installation

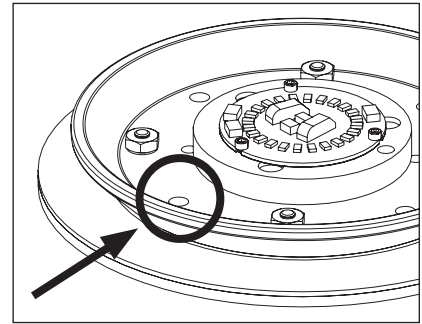
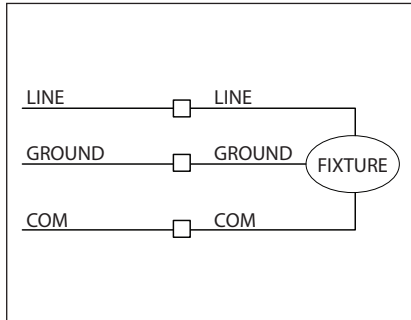
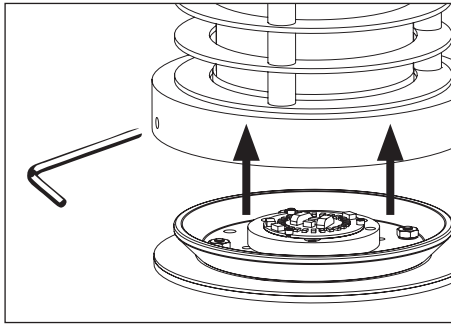

1. Loosen two (2) 1/4-20 1/2" socket stainless steel cone point set screws using a 1/8" Allen wrench. Lift fixture assembly from base plate assembly.
2. Connect primary branch circuit wiring to fixture leads using watertight wire connectors (By Others) as per NEC. Connect green fixture wire to green supply wire. **See wiring diagram.**
3. Place connections inside junction box, then attach base plate assembly to junction box using mounting hardware (By Others).

### WIRING DIAGRAM

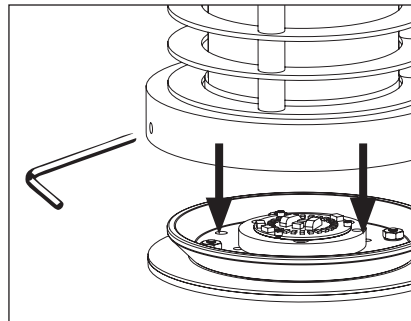
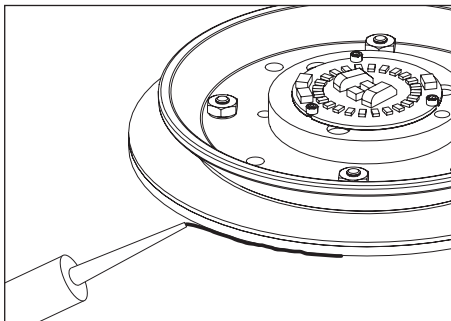

4. Place a bead of silicone-based sealant (By Others) around the mounted plate to create a watertight seal. Seal any unused hole(s) in mounting plate.
5. Slide fixture assembly over mounted base plate assembly. Lock in place with two (2) 1/4-20 1/2" socket stainless steel cone point set screws using a 1/8" Allen wrench. Ensure fixture is completely seated.

**IMPORTANT SAFETY INFORMATION LISTED ON REVERSE  
READ, FOLLOW, AND SAVE ALL SAFETY AND INSTALLATION INSTRUCTIONS**



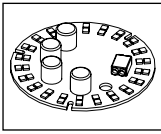

### Replacement



Warning



Hot Surface



High Voltage



Wear Gloves

**TOOLS  
NEEDED:**



- 1/8" & 5/64" Allen Wrench
- Thermal Paste (Supplied)
- Gloves

**By Others**



**IMPORTANT - WEAR GLOVES TO AVOID GETTING FINGERPRINTS ON THIS PRODUCT. MANY TEKA ILLUMINATION PRODUCTS ARE DESIGNED TO NATURALLY PATINA. OILS FROM YOUR SKIN WILL ACCELERATE THIS PROCESS WHERE TOUCHED AND ARE NEARLY IMPOSSIBLE TO REMOVE. THIS PROCESS OCCURS OVER TIME AND IS DETERMINED BY THE INSTALLATION ENVIRONMENT.**



### IMPORTANT SAFETY INFORMATION

- Product must be installed by a qualified person in a manner consistent with its intended use and in compliance with the National Electrical Code, Canadian Electrical Code, and all Local and Provincial Codes.
- Follow product label information and instructions.
- Qualified Personnel must perform all servicing or relamping of this product.
- Before wiring to power supply and during servicing or relamping, turn off power at fuse or circuit breaker before service.**

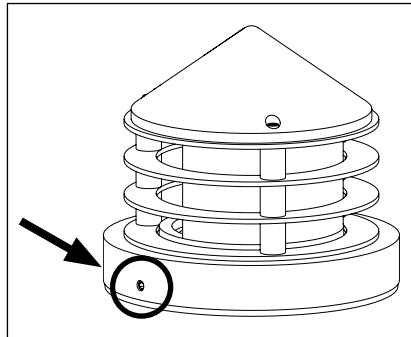

1. Remove base of fixture to access LED board by loosening two (2) 1/4-20 set screws on base with 1/8" Allen wrench.

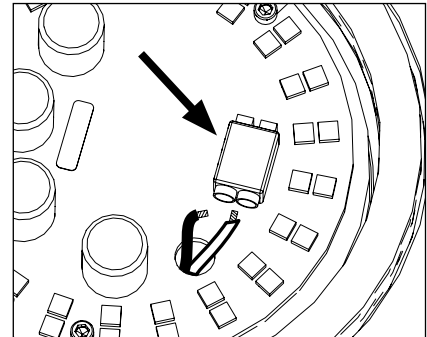

2. Gently press on tabs of LED wire holders to allow wiring to be removed from LED board.

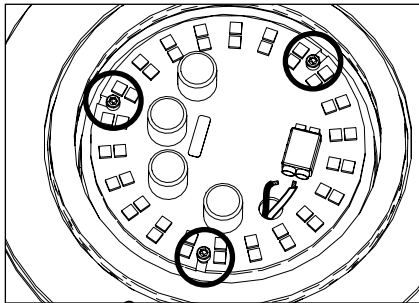

3. Loosen LED board from heatsink by using 5/64" Allen wrench on three (3) #2-56 screws on LED board.

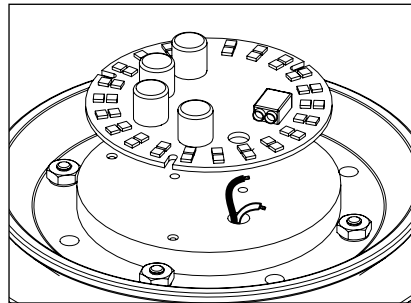

4. Remove old board by carefully pulling away.

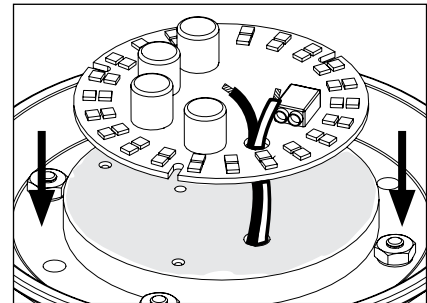

5. Spread new thermal paste in even layer on heatsink. Feed wiring from quick connect through new board.

Line up new LED board and place on heatsink.

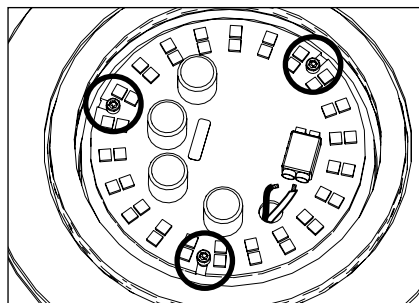

6. Secure new LED board to heatsink with three (3) #2-56 screws using 5/64" Allen wrench.

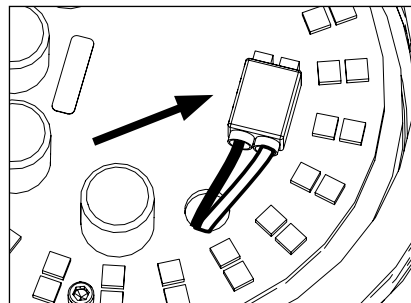

7. Connect wiring to new LED board by placing into wire connectors. Wire will 'push' into place inside holder. Black wire inserts on AC Line, while white wire inserts on Neutral.

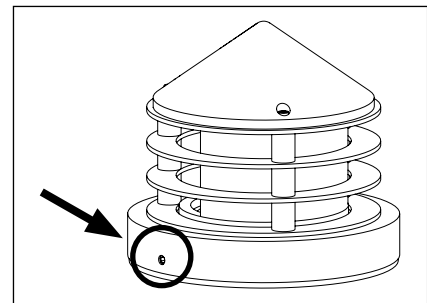

8. Reverse install cap of fixture by evenly setting base over mounting plate. Secure two (2) 1/4-20 set screws with 1/8" Allen wrench.

**IMPORTANT SAFETY INFORMATION LISTED ON REVERSE  
READ, FOLLOW, AND SAVE ALL SAFETY AND INSTALLATION INSTRUCTIONS**

