

TR600 SERIES™ 120V Magnetic Transformer

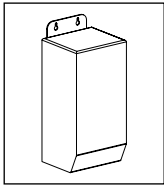

Installation Instructions



Warning



Hot Surface



High Voltage

TOOLS NEEDED:



Waterproof Wire Connectors

Mounting Hardware

By Others

INSTRUCTIONS PERTAINING TO A RISK OF FIRE, OR INJURY TO PERSONS IMPORTANT SAFETY INSTRUCTIONS

Lighted lamp is HOT!
WARNING - To reduce the risk of FIRE OR INJURY TO PERSONS:
 Turn off/unplug and allow to cool before replacing lamp.
 Lamp gets HOT quickly! Contact only switch/plug when
 turning on.
 Do not touch hot lens, guard, or enclosure (see diagram/
 picture).
 Keep lamp away from materials that may burn.
 Do not touch the lamp at any time. Use a soft cloth. Oil
 from skin may damage lamp.
 Do not operate the luminaire fitting with a missing or
 damaged shield.

SAVE THESE INSTRUCTIONS

IMPORTANT SAFETY INFORMATION - READ, FOLLOW, AND SAVE ALL SAFETY AND INSTALLATION INSTRUCTIONS

- Product must be installed by a qualified person in a manner consistent with its intended use and in compliance with the National Electrical Code, Canadian Electrical Code, and all Local and Provincial Codes.
- Follow product label information and instructions.
- Qualified Personnel must perform all servicing or relamping of this product.
- Before wiring to power supply and during servicing or relamping, turn off power at fuse or circuit breaker before service.
- The use of accessory equipment not recommended by the manufacturer or installed contrary to instructions may cause an unsafe condition. The use of damaged components may cause an unsafe condition and void product warranty.
- Do not block light emanating from product in whole or part, as this may cause an unsafe condition.
- Never operate the fixture with missing or damaged lens. Lens must be cleaned on regular basis.
- Entire fixture may become extremely hot. Do not touch hot lens or fixture body. Do not touch the lamp at any time. Use a clean, dry, soft cloth to handle the lamp. Oil from skin may damage the lamp and cause it to rupture.
- Replace lamp only with correct wattage and type of lamp marked on fixture label.
- All gaskets, o-rings and sealing surfaces must be kept clean during installation and service; failure to do this may cause an unsafe condition and void product warranty.

IMPORTANT LISTINGS AND CERTIFICATIONS

- Suitable for wet locations

Please refer to the low voltage design guide at www.tekaillumination.com/lvguide before installation for proper wire selection.

For LED sourced products, do not exceed more than 80% of the maximum load of the transformer.

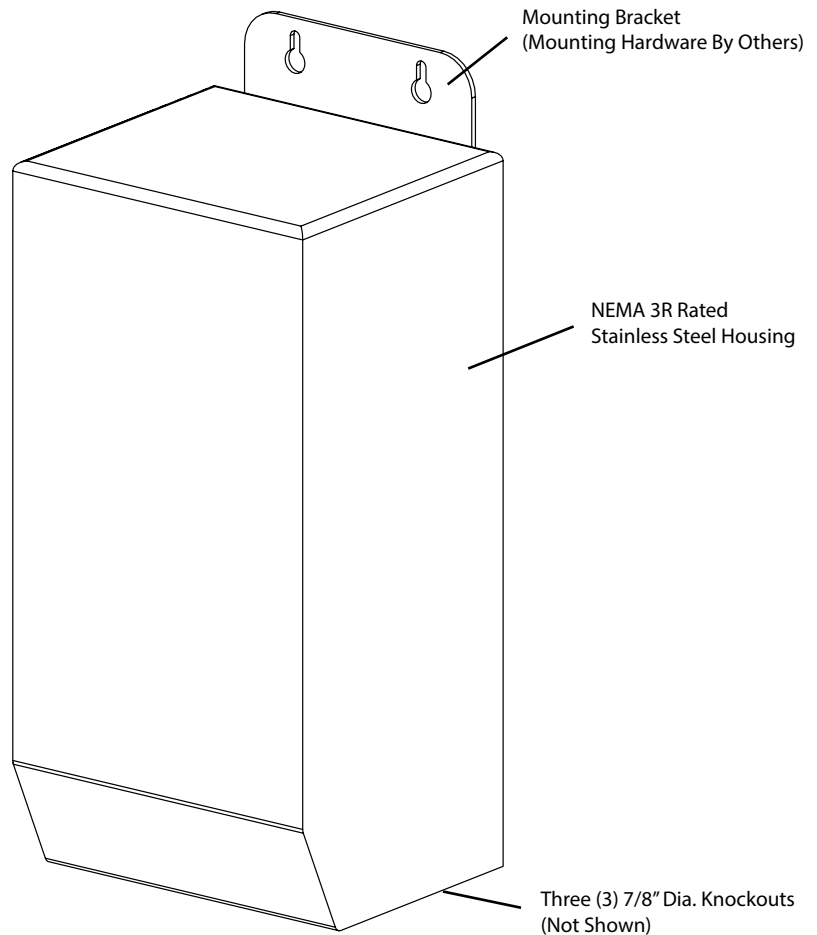

TR600-120

IMPORTANT SAFETY INFORMATION - READ, FOLLOW, AND SAVE THESE INSTALLATION INSTRUCTIONS

TEKA ILLUMINATION

40429 Brickyard Drive • Madera, CA 93636 • USA
 559.438.5800 • FAX 559.438.5900
www.tekaillumination.com • info@tekaillumination.com

RELEASED
 02-06-18

REFERENCE NUMBER
 INS-2457-00

THIS DOCUMENT CONTAINS PROPRIETARY INFORMATION OF TEKA ILLUMINATION AND ITS RECEIPT OR POSSESSION DOES NOT CONVEY ANY RIGHTS TO REPRODUCE, DISCLOSE ITS CONTENTS, OR TO MANUFACTURE, USE OR SELL ANYTHING IT MAY DESCRIBE. REPRODUCTION, DISCLOSURE OR USE WITHOUT SPECIFIC WRITTEN AUTHORIZATION OF TEKA ILLUMINATION IS STRICTLY FORBIDDEN.

TR600 SERIES™ 120V Magnetic Transformer

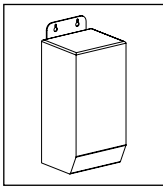

Installation Instructions

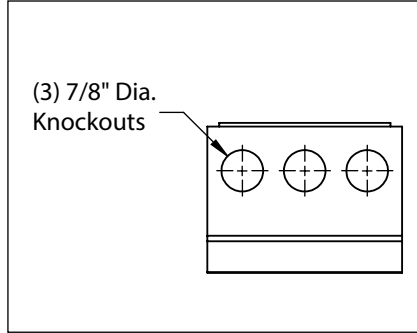
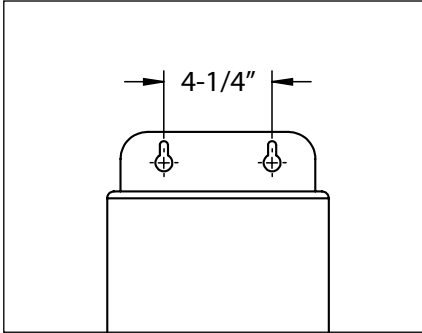

1. Mount transformer stainless steel housing with proper hardware for surface (Hardware By Others). Clearance holes are 4-1/4" apart on center.
2. Stainless steel housing has three (3) 7/8" diameter knockouts located on bottom of housing.

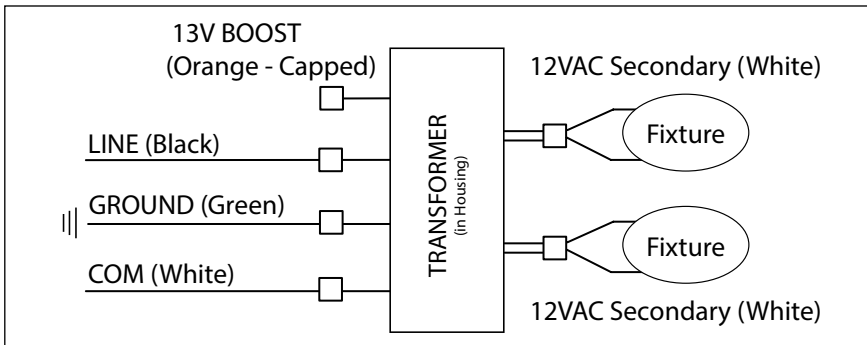

WIRING DIAGRAM - 12V Output

- 3A. For 12V output wiring: Ground incoming primary ground wire to green wire from TR600 housing. Make watertight connections from incoming primary line voltage (black) to black primary side of transformer. Connect incoming primary common (white) to white primary side of transformer. Orange boost wire from primary side of transformer must be capped for 12V wiring. Connect secondary sides of transformer (white) to fixture leads. **See wiring diagram.**

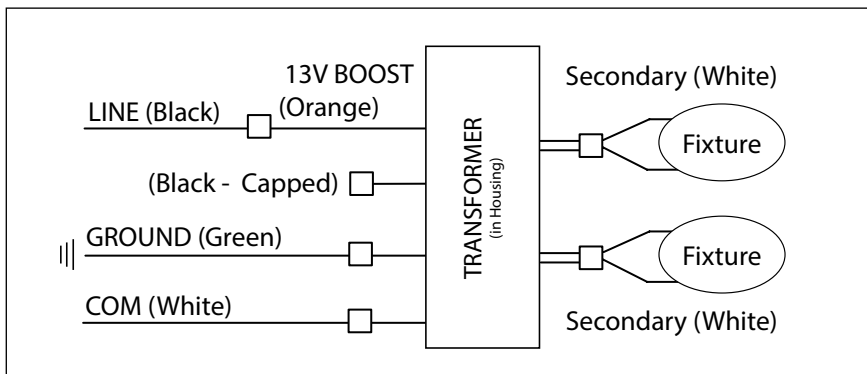

WIRING DIAGRAM - 13V Output

- 3B. For 13V output wiring: Ground incoming primary ground wire to green wire from TR600 housing. Make watertight connections from incoming primary line voltage (black) to orange boost wire from primary side of transformer. Connect incoming primary common (white) to white primary side of transformer. Black wire from transformer primary side must be capped for 13V wiring. Connect secondary sides of transformer (white) to fixture leads. **See wiring diagram.**

**IMPORTANT SAFETY INFORMATION LISTED ON REVERSE
READ, FOLLOW, AND SAVE ALL SAFETY AND INSTALLATION INSTRUCTIONS**



TR600 SERIES™ 277V Magnetic Transformer

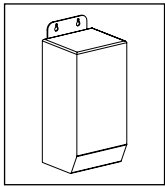

Installation Instructions



Warning



Hot Surface



High Voltage

TOOLS NEEDED:



Waterproof Wire Connectors

Mounting Hardware

By Others

INSTRUCTIONS PERTAINING TO A RISK OF FIRE, OR INJURY TO PERSONS IMPORTANT SAFETY INSTRUCTIONS

Lighted lamp is HOT!

WARNING - To reduce the risk of FIRE OR INJURY TO PERSONS:
Turn off/unplug and allow to cool before replacing lamp.
Lamp gets HOT quickly! Contact only switch/plug when
turning on.

Do not touch hot lens, guard, or enclosure (see diagram/
picture).

Keep lamp away from materials that may burn.
Do not touch the lamp at any time. Use a soft cloth. Oil
from skin may damage lamp.

Do not operate the luminaire fitting with a missing or
damaged shield.

SAVE THESE INSTRUCTIONS

IMPORTANT SAFETY INFORMATION - READ, FOLLOW, AND SAVE ALL SAFETY AND INSTALLATION INSTRUCTIONS

- Product must be installed by a qualified person in a manner consistent with its intended use and in compliance with the National Electrical Code, Canadian Electrical Code, and all Local and Provincial Codes.
- Follow product label information and instructions.
- Qualified Personnel must perform all servicing or relamping of this product.
- Before wiring to power supply and during servicing or relamping, turn off power at fuse or circuit breaker before service.
- The use of accessory equipment not recommended by the manufacturer or installed contrary to instructions may cause an unsafe condition. The use of damaged components may cause an unsafe condition and void product warranty.
- Do not block light emanating from product in whole or part, as this may cause an unsafe condition.
- Never operate the fixture with missing or damaged lens. Lens must be cleaned on regular basis.
- Entire fixture may become extremely hot. Do not touch hot lens or fixture body. Do not touch the lamp at any time. Use a clean, dry, soft cloth to handle the lamp. Oil from skin may damage the lamp and cause it to rupture.
- Replace lamp only with correct wattage and type of lamp marked on fixture label.
- All gaskets, o-rings and sealing surfaces must be kept clean during installation and service; failure to do this may cause an unsafe condition and void product warranty.

IMPORTANT LISTINGS AND CERTIFICATIONS

- Suitable for wet locations

Please refer to the low voltage design guide at www.tekaillumination.com/lvguide before installation for proper wire selection.

For LED sourced products, do not exceed more than 80% of the maximum load of the transformer.

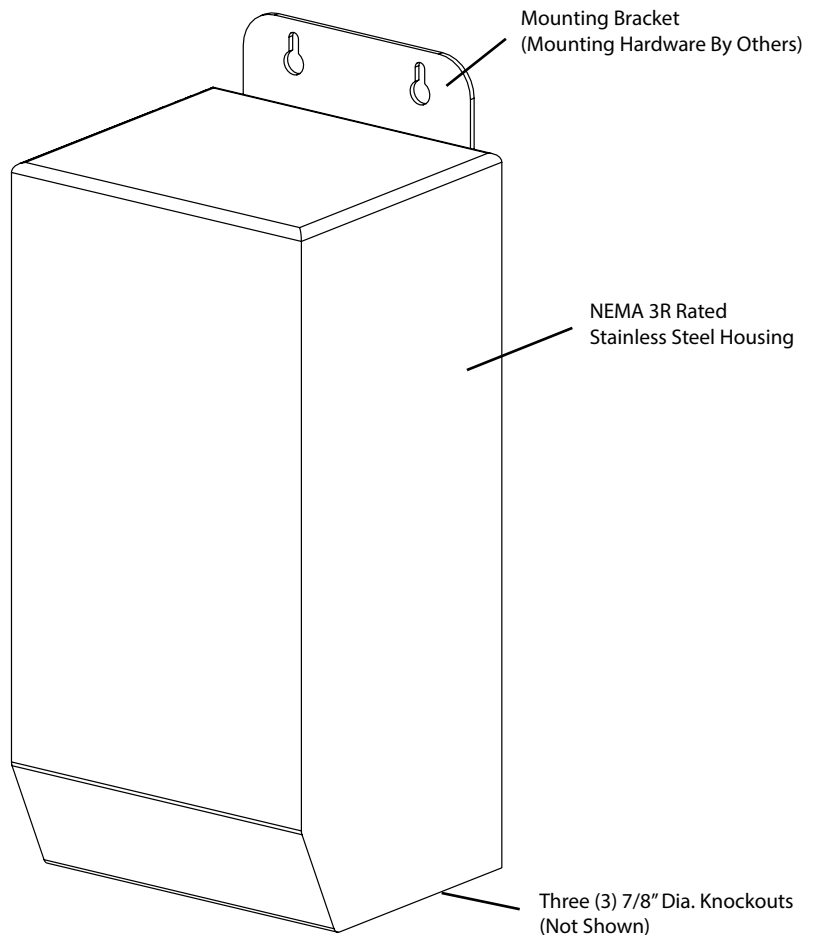

TR600-277

IMPORTANT SAFETY INFORMATION - READ, FOLLOW, AND SAVE THESE INSTALLATION INSTRUCTIONS

TEKA ILLUMINATION

40429 Brickyard Drive • Madera, CA 93636 • USA
559.438.5800 • FAX 559.438.5900
www.tekaillumination.com • info@tekaillumination.com

RELEASED
02-06-18

REFERENCE NUMBER
INS-2460-00

THIS DOCUMENT CONTAINS PROPRIETARY INFORMATION OF TEKA ILLUMINATION AND ITS RECEIPT OR POSSESSION DOES NOT CONVEY ANY RIGHTS TO REPRODUCE, DISCLOSE ITS CONTENTS, OR TO MANUFACTURE, USE OR SELL ANYTHING IT MAY DESCRIBE. REPRODUCTION, DISCLOSURE OR USE WITHOUT SPECIFIC WRITTEN AUTHORIZATION OF TEKA ILLUMINATION IS STRICTLY FORBIDDEN.

TR600 SERIES™ 277V Magnetic Transformer

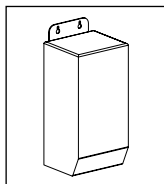

Installation Instructions

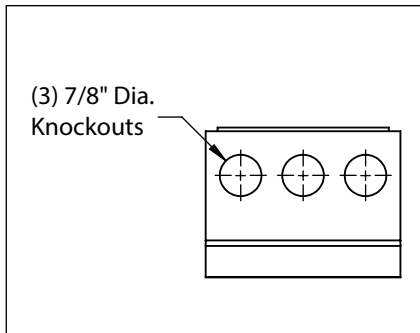
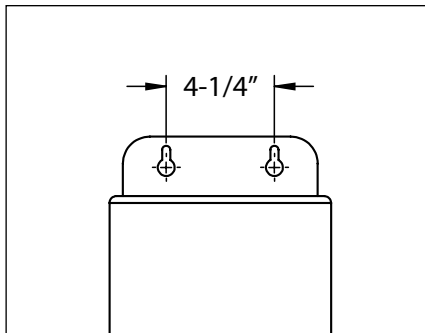

1. Mount transformer stainless steel housing with proper hardware for surface (Hardware By Others). Clearance holes are 4-1/4" apart on center.
2. Stainless steel housing has three (3) 7/8" diameter knockouts located on bottom of housing.

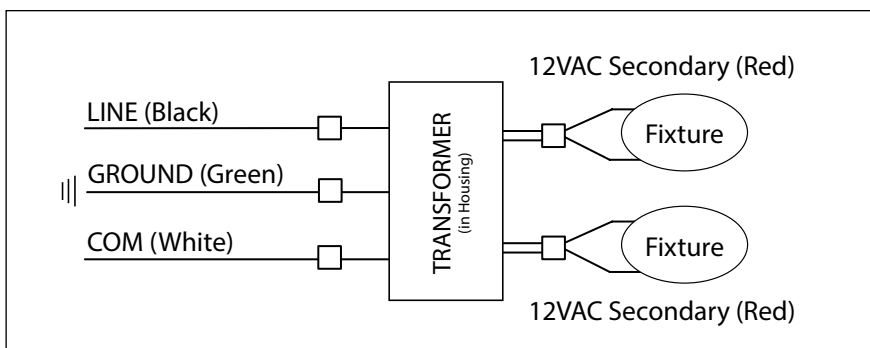

WIRING DIAGRAM - 12V Output

- 3A. For 12V output wiring: Ground incoming primary ground wire to green wire from TR600 housing. Make watertight connections from incoming primary line voltage (black) to black primary side of transformer. Connect incoming primary common (white) to white primary side of transformer. Connect secondary sides of transformer (red) to fixture leads. **See wiring diagram.**

**IMPORTANT SAFETY INFORMATION LISTED ON REVERSE
READ, FOLLOW, AND SAVE ALL SAFETY AND INSTALLATION INSTRUCTIONS**



TEKA ILLUMINATION

40429 Brickyard Drive • Madera, CA 93636 • USA
559.438.5800 • FAX 559.438.5900
www.tekaillumination.com • info@tekaillumination.com

RELEASED
02-06-18

REFERENCE NUMBER
INS-2460-00